

envirolyte[®]

INNOVATING FOR A BETTER WORLD



Technical Data Sheet of
ela900ANW
analyte (HClO) generator

External view of ela900ANW

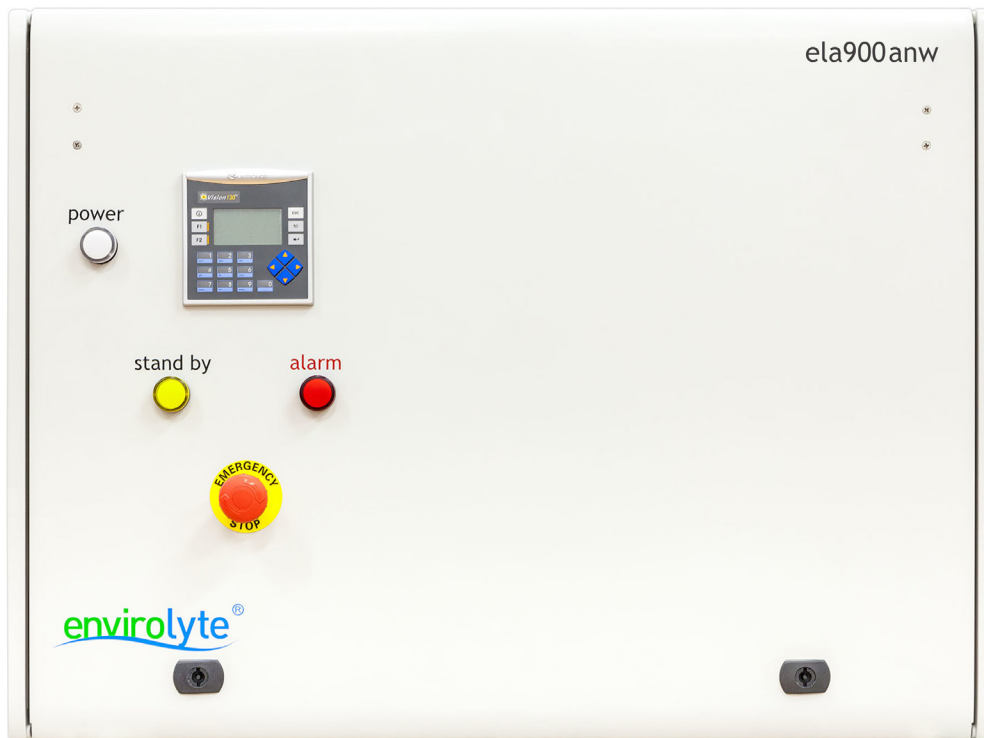

Specifications/Models	ela900ANW
Output capacity of analyte	Total output ~90 LPH of ANK - Neutral Analyte with ~500 ppm of FAC, pH ~7-7.5
pH of HClO	Regulation of pH in the range pH ~2.5-7.5 is optional and should be specified when ordering
NaCl consumption	1.2-1.5 g per 1 L of 500 ppm HClO Lower salt consumption on request
Catholyte flow rate	~0.45 LPH
Weight of the generator	~45 kg
Crated weight	~55 kg

On site installations of ela900ANW



Dimensions of ela900ANW

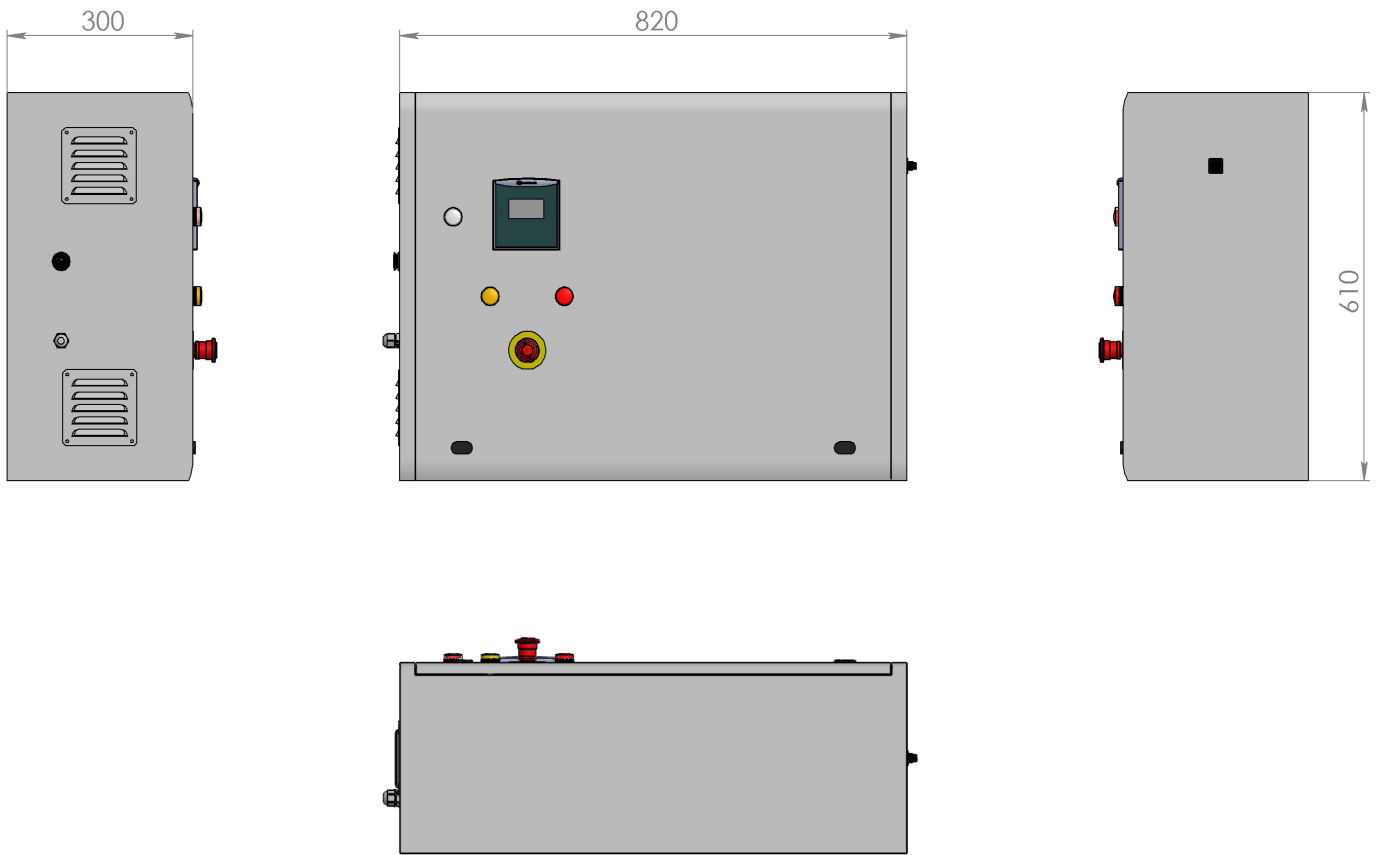

Crated dimensions of ela900ANW

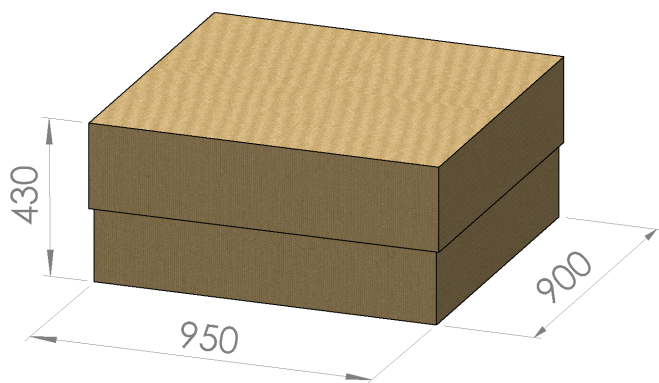

Mounting dimensions of ela900ANW

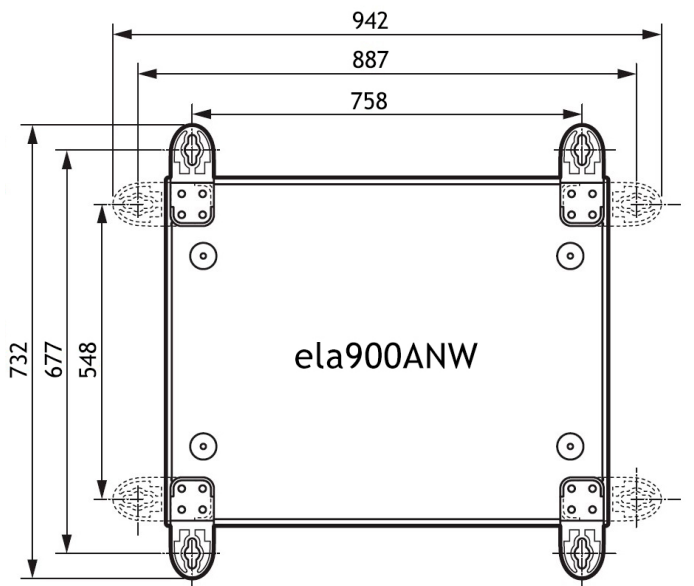

Power supply	230 VAC/ 50-60 Hz . Alternatives are possible
Power consumption	~ 0.550 kW/h
Automated flushing	+
Acid pump	+
Brine pump	+
Input valve	+
Flow and pressure switchers/ controllers	+
Temperature switchers on the cells	+
Durability	Able to stand up to adverse conditions such as dust and high humidity
Life expectancy of electrodes and membrane	5-7 years
Type of cell	<p>R/RT-90ANE</p>
Fittings	LLDPE tubing + Kynar fittings
PLC Unitronics	<p>Vision 130</p> <p>Alternatives are possible</p>

Accessories

- Main water tubing ~ 2 m
- Anolyte tubing ~ 2 m
- Catholyte tubing ~ 2 m
- Brine tubing ~ 2 m
- Acid tubing ~ 2 m
- Salt filter – 1 pcs
- Mains water fitting – 1 pcs
- Wall mounting lugs – 1 set
- Level switch for anolyte tank – 1 set

Options

- Produced in 2 boxes: 720x510 mm or 820x610 mm

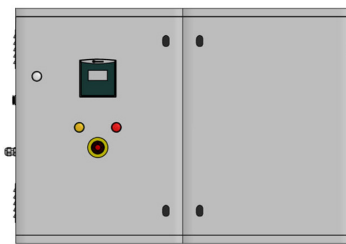

In two 720x510 mm boxes

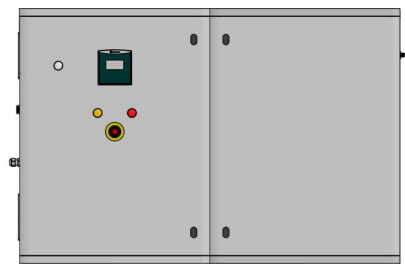

In two 820x610 mm boxes

- Multicolor touchscreen PLC V570



- Remote control through Ethernet, Modbus TCP IP or GSM
- Inline pH sensor
- Inline ORP sensor
- Non-contact level sensor



Enviolyte Industries International Ltd.

Sarruse 16, Tallinn 13816, Estonia